

Sinteso™ / Cerberus™ PRO

Power supply (70 W)

FP2015-A1



This power supply can be installed in fire control panels or in additional housing intended for this purpose. When it is used in additional housing, the power supply must be monitored by the fire control panel.

- Output power 70 W
- Short-circuit-proof
- Current limited
- Mains voltage monitored
- Batteries monitored
- Battery charging with temperature compensation
- Uninterruptible power supply in battery operation
- Supplies other consumers (complies with EN 54 and VdS)
- AC 230 V or AC 115 V

Properties

- The power supply (70 W) converts mains voltage to system voltage and charges the batteries.
- The DC 24 V system voltage is electrically isolated.
- For the supply of consumers in accordance with EN 54-4 and VdS.
- The output voltage is short-circuit-proof and battery charging is current-limited.
- Must not be connected in parallel.
- The battery charge voltage is regulated with temperature compensation.
- A jumper can be used to switch the mains voltage from AC 230 V to AC 115 V.

Monitoring of mains voltage and the batteries

- A failure of the AC 230 V supply voltage or a higher internal battery resistance are detected and an error message is generated.

Uninterruptible power supply

- If the mains voltage fails, the supply switches automatically from mains operation to battery operation.

Protecting the battery against total discharge

- When the final voltage is reached, the battery switches off automatically.

Use

Power supply FP2015-A1



The power supply (70 W) is for the following uses:

- As an optional power supply for the following fire terminals
 - Sinteso: FT2040
 - Cerberus™ PRO: FT724
- As an extension for FS20-/FS720 empty housing
 - Sinteso: FH2001-A1 housing (Eco), FH2002-A1 housing (Standard)
 - Cerberus™ PRO: FH7201-Z3 housing (Eco), FH7202-Z3 housing (Standard)

Housing (Eco) FH7201-Z3



- Empty housing (Eco), can be used for power supply (70 W)
- Dimensions without cover cap: W x H x D 430 x 398 x 80 mm
- Installable batteries: Max. 7 Ah 430 x 398 x 80 mm

Housing (Standard) FH7202-Z3



- Empty housing (Standard), can be used for power supply (70 W)
- Dimensions without cover cap: W x H x D 430 x 398 x 160 mm
- Installable batteries: Max. 12 Ah, together with power supply (70 W)

Housing (Eco) FH2001-A1



- Empty housing (Eco), can be used for power supply (70 W)
- Dimensions without cover cap: W x H x D 430 x 398 x 80 mm
- Installable batteries: Max. 7 Ah

Housing (Standard) FH2002-A1



- Empty housing (Standard), can be used for power supply (70 W)
- Dimensions without cover cap: W x H x D 430 x 398 x 160 mm
- Installable batteries: Max. 12 Ah, together with power supply (70 W)

Type Overview

Type	Designation	Order no.	Weight
FP2015-A1	Power supply (70 W)	S54400-B121-A1	0.576 kg
FA2003-A1	Battery (12 V / 7 Ah / VdS)	A5Q00019353	2.450 kg
FA2004-A1	Battery (12 V / 12 Ah / VdS)	A5Q00019354	3.930 kg
FA2005-A1	Battery (12 V / 17 Ah / VdS)	A5Q00019677	5.640 kg
Additionally, for use in FC36x fire control panels:			
BAT12-25	Battery (12 V / 25 Ah / VdS)	S54302-Z102-A1	8.180 kg

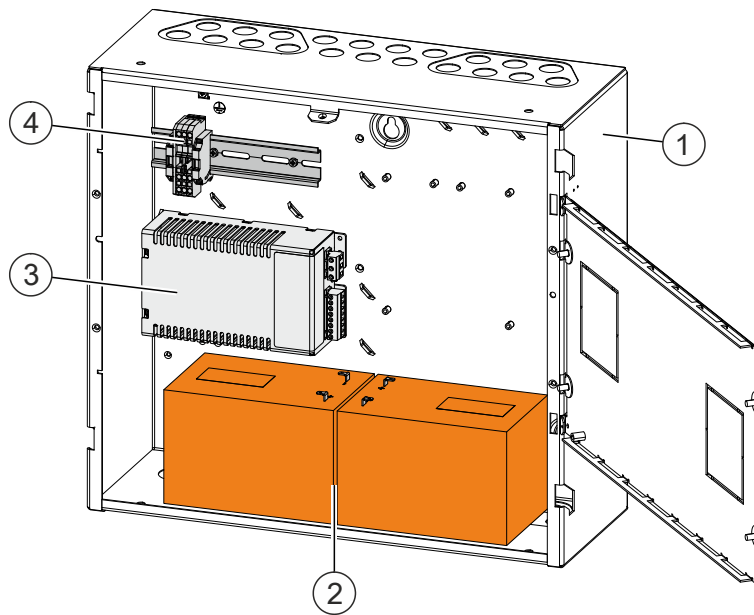

Fig. 1: Arranging the components, using the housing (Standard) as an example

Components		Designation	Notes
1	Housing (Standard)	FH2002-A1 FH7202-Z3	Incl. U-rail, 150 mm
2	Batteries	--	7...12 Ah, depending on housing
3	Power supply (70 W)	FP2015-A1	Contained in FP120-Z1
4	Mains connection terminals	--	Contained in FP120-Z1

Product documentation

Document ID	Title
008836	FS20 Fire Detection System - System Description
008837	FS20 Fire detection system - Product Data
008843	FS20 Fire detection system - Planning
008851	FS20 Fire detection system - Mounting / Installation
A6V10210355	FS720 Fire detection system - System Description
A6V10210362	FS720 Fire detection system - Planning
A6V10210368	FS720 Fire detection system - Product Data
A6V10210390	FS720 Fire detection system - Mounting / Installation
A6V10421795	FC36x Fire control panel - Technical manual
A6V10411051	FP2015-A1 Power supply (70 W) - Technical manual

Related documents such as the environmental declarations, CE declarations, etc., can be downloaded from the following Internet address:

<https://siemens.com/bt/download>

Notes

Disposal

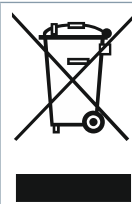

The device is considered an electronic device for disposal in accordance with the European Guidelines and may not be disposed of as domestic garbage.

- Dispose of the device through channels provided for this purpose.
- Comply with all local and currently applicable laws and regulations.
- Dispose of empty batteries in designated collection points.



⚠ WARNING

Connecting batteries in parallel

Risk of explosion and fire

- Never switch batteries in parallel.
- If you need more power, you must use batteries with a higher capacity.

Technical data

Mains supply	Voltage	AC 97...127 V, AC 196...253 V, 50 / 60 Hz
	Current	0.5...1 A
	Power consumption	Max. 90 VA
System supply output	Designation	'Usys'
	Voltage	DC 20.5...28.6 V, depending on charge and temperature
	Current:	
	• Maximum output current with battery charge ($I_{\max a}$)	0.9 A
	• Maximum output current without bat- tery charge ($I_{\max b}$)	2.5 A
	• Minimum output current (I_{\min})	0.05 A
	Output power	70 W
	Ripple	Max. 5 %
Battery supply output	Designation	'Accu'
	Voltage	DC 20.5...28.6 V, depending on charge and temperature
	Charging current	Max. 1.6 A, the charging current is reduced at full load
	Connectable batteries	<ul style="list-style-type: none"> • 2x 12 V / 7...17 Ah • For FC36x fire control panels: 2x 12 V / 7...25 Ah Battery types recommended by Siemens in acc. with planning document
	Battery internal resistance (R_{\max})	Max. 1 Ω , batteries incl. line
	Batteries are monitored for	<ul style="list-style-type: none"> • Short-circuit • Open line • Presence
	Low discharge protection	Battery voltage DC 20.5 V...21.0 V

Mains fault monitoring signal	Designation	'Mains'
	Active in event of	<ul style="list-style-type: none"> No mains voltage Signaling within 10 s
	Design	Open collector
Battery fault monitoring signal	Designation	'Battery'
	Active in event of	<ul style="list-style-type: none"> Battery fault Battery voltage <DC 21.0 V
	Design	Open collector
Connections	Mains supply, battery supply and monitoring signals	Plug-type connections
Ambient conditions	Maximum height above sea level	4000 m
Mechanical data	Dimensions (W x H x D)	95 x 170 x 54 mm
	Weight	576 g
Approvals	VdS	G213083
	LPCB	126, 531

Dimensional drawings

