

Vandal Resistant IR Illuminator

IRLMS 6 LED

Deliver high power infrared light for CCTV & IP camera at night time and improve performance of camera to get clear pictures.



Product Features

- Precise secondary optical technology

The latest LED technology assures outstanding performance of LED with excellent luminous efficiency and more uniform illumination

- Independent innovation of high efficiency power drive schemes

Low failure rate of products is guaranteed because of professional in-house optimized independent circuit technology widely used in our LED illuminators for more than 5 years

- High thermal conductivity aluminum

Excellent thermal management not only reduces excess heat and brightness decay of LED but also ensures efficient, reliable and continuous operation of LED throughout its lifetime as 50,000 hours.

- Manual adjustable photocell and brightness

Easily set the time of Turn-on illuminator to meet any environmental brightness requirement and dim the brightness of illuminator to suitable light effect.

- Vandal resistant

Vandal resistant panel protects against hammer, stone and continuous thumping in a certain range.

- Energy saving technology

All illuminators has energy saving circuit with low electrical power consumption.

- Thinner and lighter design

Our patent owned housing is designed for simple installation and easy operation to reduce construction difficulty.



Basic Function

- To improve performance of the weak light camera, thereby enhancing the picture effects at night.
- Conventional night monitoring
- The function of video analysis at night
- Reduce signal noise and other image distortion
- Reduce the network bandwidth requirements
- Energy saving by power factor correction
- Lower cost of installing and wiring
- Indoor and outdoor use

Viewing picture at night



With IR light



Without IR light

Picture



Product Certificate



Technical Specification

LED type: 6 pieces high power IR LED
Wavelength: 740nm/850nm/940nm
Beam angle: 15 to 120°
Beam distance: 80m to 12m (850nm)
Bracket: wall mount bracket
Working voltage: DC12V/AC24V
Current: 800mA/500mA (adjustable) (850nm)
Day/night switch: automatic
Working temperatures: -30°C to 50°C
Protection level: IP66
Color: black
Panel: Vandal proof PC panel
Housing: aluminum die-casting housing
N.W.: 0.53KG
G.W.: 0.6KG
Packing dimension: 145*135*95mm

Adjustment and installation



Warning

1. Don't overexert when turning the plastic bolt and knob to avoid damage.
2. Turn counterclockwise to loosen the plastic bolt, clockwise to tighten.
3. Make sure waterproof circle is on the plastic bolt to avoid water in.
4. Don't open the case without permission.

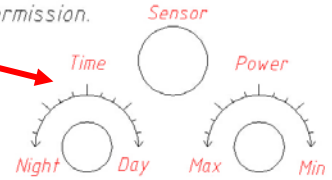

This side must be downward!

Drawing

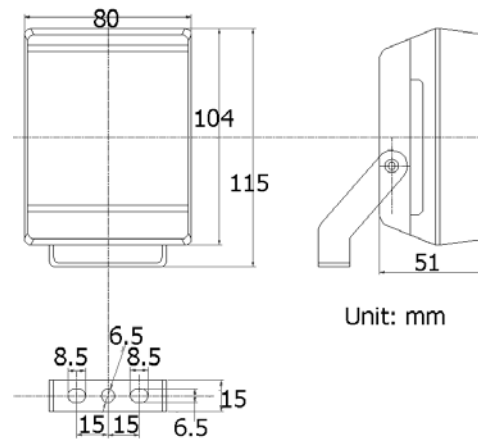

Model for Selection

Model	Beam angle	IR Distance (850nm)
IRLMS15/80/12	15°	80m
IRLMS30/60/12	30°	60m
IRLMS45/40/12	45°	40m
IRLMS60/22/12	60°	22m
IRLMS90/16/12	90°	16m
IRLMS120/12/12	120°	12m

*IR distance is tested by Sony 1/3 CCD Camera with 0.01LX.

To achieve the distance needed, please pay attention to your camera specification and lens before purchase. It is normal phenomenon that distance may vary due to different cameras and lens.