

MVL-HF1228-05S

12mm F2.8 M12 Mount Lens

M12 series lens is designed for machine vision applications with excellent imaging quality from near to infinity. It is suitable for board cameras with different resolutions. Adapt for measurement, positioning, defect detection, code scanning and other fields.



Key Features

- Optimization design for machine vision
- High resolution, High consistency of picture definition
- Low Distortion, High relative illumination
- S-Mount (M12 * 0.5), Easy system integration

Dimension

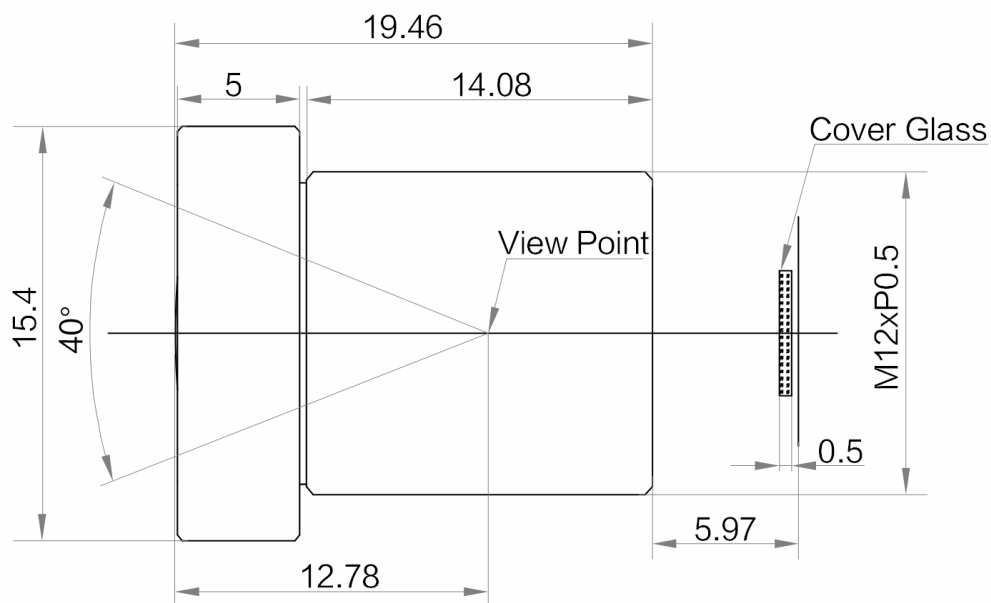

Unit: mm



Specification

Parameter	Model	MVL-HF1228-05S
		12mm F2.8 M12 Mount Lens
Performance		
Focal Length		12 mm
F-Number		F2.8
Image Size		Φ9 mm(1/1.8")
TV Distortion		<0.2%
Working Distance Range		100 ~ 850 mm
Field of View		D (8.86 mm) : 41° H (7.37 mm) : 34° V (4.91 mm) : 23°
Mechanical		
Mount		S-Mount
TTL		25.4 ~ 26.9 mm
Dimension		Φ15.4 mm × 19.46 mm
Temperature		-10 ~ 50°C
General		
Certification		RoHS2.0

HIKROBOT

Hangzhou Hikrobot Technology Co., Ltd.

No.399 Danfeng Road, Binjiang District, Hangzhou 310051, China.

en.hikrobotics.com

Copyright Hikrobot

Hangzhou Hikrobot Technology Co., Ltd. All Rights Reserved. Hangzhou Hikrobot Technology does not tolerate any infringement. Any organization or individual may not imitate or reproduce in whole or in part of the content. The data herein is based on Hikrobot's internal evaluation. Actual data may vary depending on specific configuration and operating condition. The information herein is subject to change without notice All the content has been checked conscientiously. Nevertheless, Hikrobot shall not be liable to damages resulting from errors, inconsistencies or omissions.