

MVL-HF3524M-10MP

1/1.8" 35mm 10MP FA LENS

HF-P series FA Lens are optimized for machine vision light sources and sensor, with high resolution, excellent image quality, high transmittance and good stability. Featured with fixed focal length, manual aperture and compact size, it is suitable for machine vision industry applications and ideal for industrial cameras.



Key Features

- Ultra high resolution and consistency of image clarity
- Bigger aperture, lower distortion and higher relative illumination rate
- Achromatic optical system design, Better imaging performance with color camera
- Excellent vibration resistance performance, optical axis shifting within pixel level
- Good stability at high and low temperature
- Multilayer and broadband coating design, compatible with visible and near-infrared applications

Distortion:

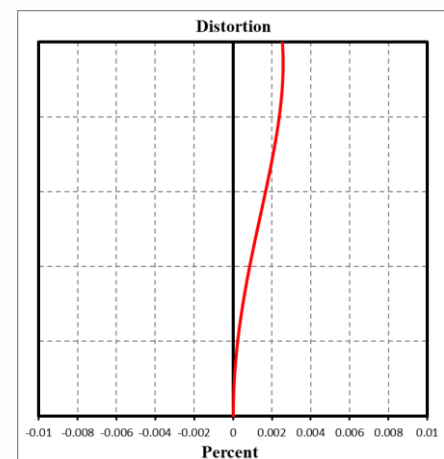

MTF:

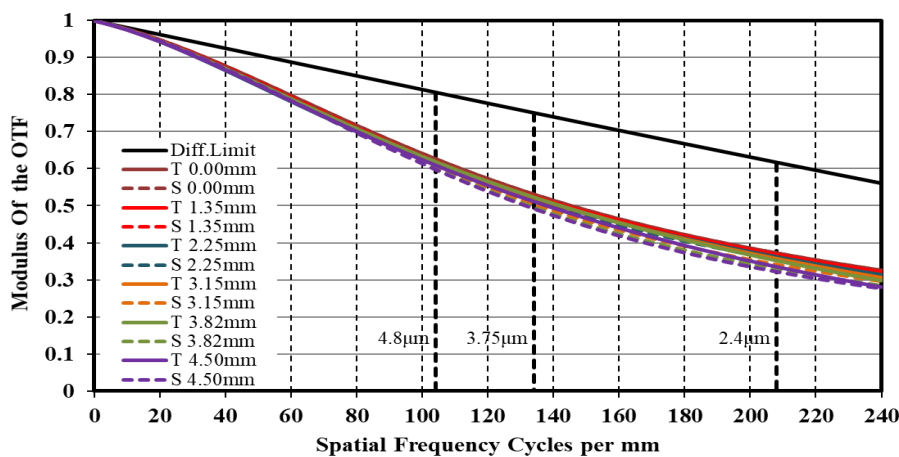

Relative Illumination:

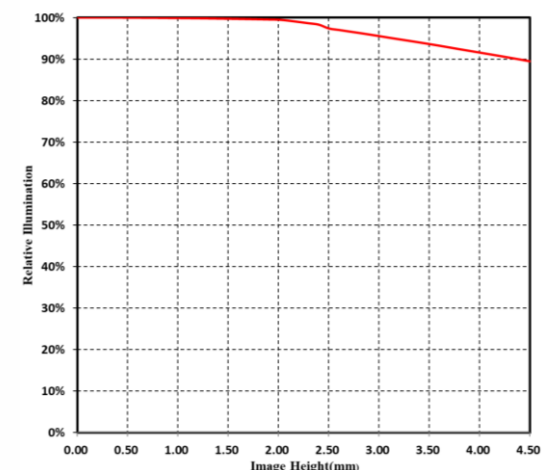

Note: The above curves are the simulate results based on F2.4, $\beta=-0.074$, WD=500 mm.



Specification

Model	MVL-HF3524M-10MP
Parameter	Fixed focal length, Manual iris, 10MP, FA Lens
Performance	
Focal Length	35 mm
F-Number	F2.4~F16
Image Size	Φ9 mm(1/1.8")
Distortion	0.01%
Minimum Operation Distance	0.15 m
Field of View	D (8.96mm): 13.47° H (7.38mm): 11.03° V (4.92mm): 7.34°
Mechanical	
Iris Control	Manual
Focus Control	Manual
Filter Thread	M27 × 0.5
Mount	C-Mount
Flange Back Length	17.526 mm
Dimension	Φ29 × 51.68 mm
Weight	85.1 g
Temperature	-10 ~ 50°C
General	
Certification	RoHS2.0

Dimension

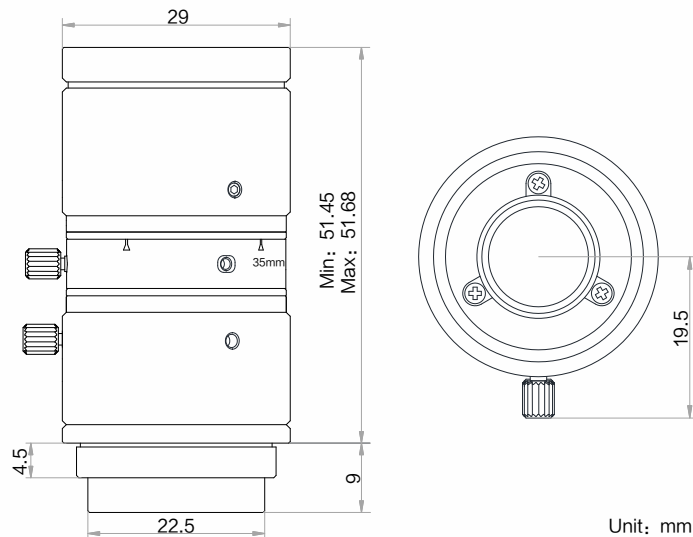

Field of View

Extension (mm)	Working Distance (mm)		Magnification	Field of View (mm)			
				1/1.8"		1/2"	
				H(7.38mm)	V(4.92mm)	H(6.22mm)	V(4.67mm)
10	near	86.5	-0.565	13.08	8.72	11.02	8.27
	far	146	-0.288	25.65	17.10	21.62	16.23
5	near	107.4	-0.422	17.50	11.67	14.75	11.07
	far	266	-0.145	51.00	34.00	42.98	32.27
2	near	128.5	-0.336	21.97	14.65	18.52	13.90
	far	625	-0.058	126.70	84.48	106.79	80.19
1	near	138.2	-0.308	24.02	16.01	20.25	15.20
	far	1200	-0.030	248.04	165.40	209.08	157.00
0		150	-0.279	26.51	17.67	22.34	16.77
		200	-0.199	37.07	24.71	31.24	23.45
		250	-0.155	47.62	31.74	40.13	30.12
		300	-0.127	58.16	38.77	49.02	36.80
		350	-0.107	68.71	45.81	57.91	43.48
		400	-0.093	79.26	52.83	66.80	50.15
		450	-0.082	89.81	59.87	75.69	56.83
		500	-0.074	100.35	66.90	84.58	63.50
		550	-0.067	110.87	73.92	93.45	70.16
		600	-0.061	121.44	80.96	102.35	76.85
		650	-0.056	131.98	88.00	111.24	83.53
		700	-0.052	142.52	88.00	120.12	83.53
		800	-0.045	163.58	109.07	137.87	103.52
	900	-0.040	184.70	123.15	155.68	116.90	
	1000	-0.036	184.70	123.15	173.46	116.90	

HIKROBOT

Hangzhou Hikrobot Co., Ltd.
en.hikrobotics.com

© Hangzhou Hikrobot Co., Ltd. All Rights Reserved.

Hangzhou Hikrobot does not tolerate any infringement. Any organization or individual may not imitate or reproduce in whole or in part of the content. The data herein is based on Hikrobot's internal evaluation. Actual data may vary depending on specific configuration and operating condition. The information herein is subject to change without notice. All the content has been checked conscientiously. Nevertheless, Hikrobot shall not be liable to damages resulting from errors, inconsistencies or omissions.