

MVL-KF1228M-12MP 1.1" 12mm 12MP FA LENS

KF series FA Lens are optimized for machine vision light sources and sensors, with high resolution, excellent image uniformity, high transmittance and good stability. Featured with fixed focal length, manual aperture and compact size, it is suitable for machine vision industry applications.



Key Features

- High resolution, high definition of the whole image
- Low distortion, high illumination relative
- Excellent mechanism design, improve the shock resistance and high/low temperature stability
- Multilayer wide band coating, ensuring high transmittance of visible and near infrared light
- Support ultra short working distance, maintaining excellent optical properties at different object distances

Distortion

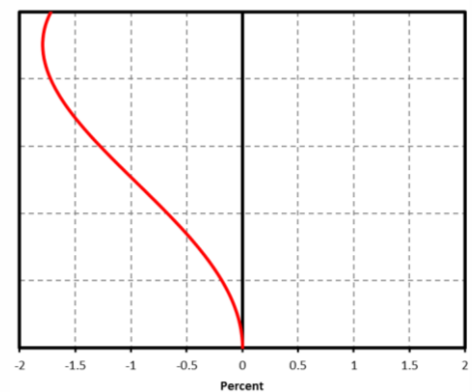

MTF

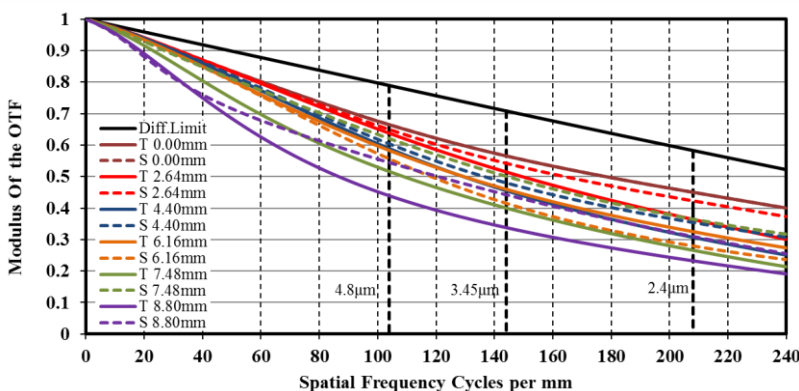

Relative Illumination

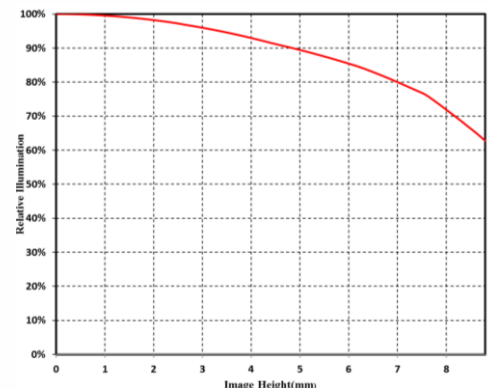

Note: The above curves are the simulate results based on F2.8, $\beta=-0.038$, WD=300 mm.



Specification

	Model	MVL-KF1228M-12MP
Parameter		Fixed focal length, Manual iris, 12MP, FA Lens
Performance		
Focal Length		12 mm
F-Number		F2.8 ~ F16
Image Size		Φ17.6 mm(1.1")
Optical Distortion		-1.79%
Minimum Operation Distance		0.1 m
Field of View		D (17.52mm): 70.5° H (14.14mm): 59.8° V (10.35mm): 46.2°
Mechanical		
Iris Control		Manual
Focus Control		Manual
Mount		C-Mount
Flange Back Length		17.526 mm
Dimension		Φ47 × 56.99 mm
Weight		186 g
Temperature		-10 ~ 50 °C
General		
Certification		RoHS2.0

Dimension

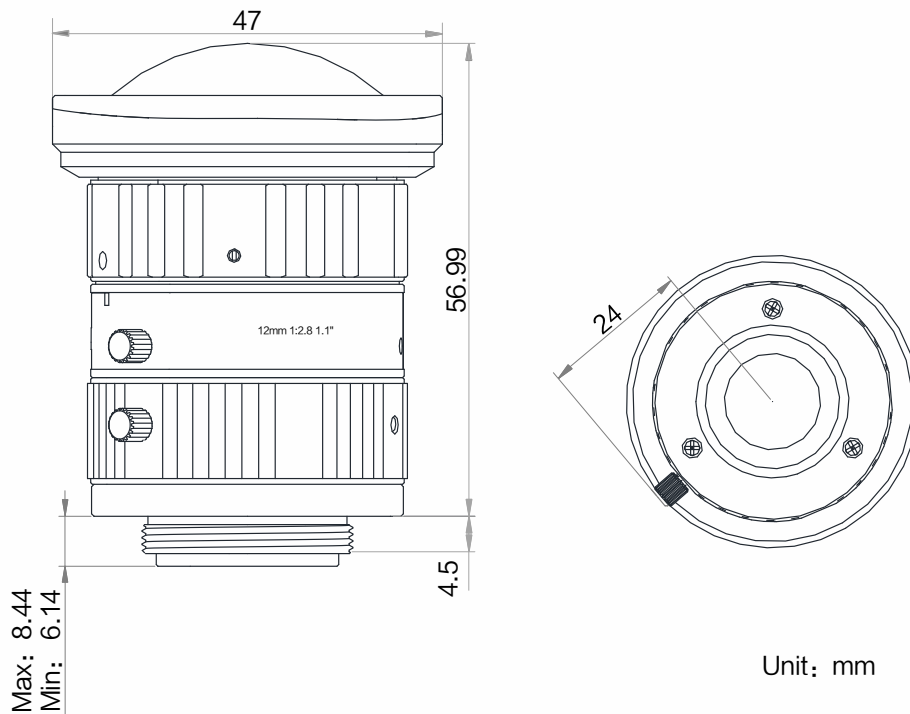

Field of View

Extension (mm)	Working Distance (mm)	Magnification	Field of View (mm)					
			1.1"		1"		2/3"	
			H(14.14mm)	V(10.35mm)	H(12.45mm)	V(9.83mm)	H(8.45mm)	V(7.07mm)
2	25	-0.256	58.39	41.75	50.84	39.54	33.76	28.08
1	50	-0.169	87.61	62.98	76.49	59.68	51.02	42.49
	75	-0.126	116.61	84.19	102.04	79.82	68.31	56.92
0	100	-0.100	145.95	105.37	127.71	99.90	85.49	71.25
	150	-0.071	203.80	147.63	178.63	140.01	119.92	100.00
	200	-0.055	261.51	189.80	229.44	180.04	154.27	128.69
	250	-0.045	319.15	231.94	280.20	220.04	188.60	157.37
	300	-0.038	376.77	274.05	330.93	260.01	222.92	186.03
	350	-0.033	434.36	316.16	381.64	299.98	257.22	214.69
	400	-0.029	491.94	358.25	432.34	339.94	291.52	243.34
	450	-0.026	549.52	400.34	483.04	379.89	325.81	271.99
	500	-0.024	607.09	442.43	533.74	419.84	360.11	300.63
	550	-0.022	664.65	484.51	584.43	459.79	394.40	329.28
	600	-0.020	722.21	526.59	635.11	499.74	428.69	357.92
	650	-0.018	779.77	568.67	685.80	539.68	462.97	386.56
	700	-0.017	837.33	610.75	736.48	579.63	497.26	415.21
	750	-0.016	894.89	652.83	787.16	619.57	531.54	443.85
	800	-0.015	952.44	694.90	837.84	659.51	565.83	472.49
	850	-0.014	1010.00	736.98	888.52	699.45	600.11	501.13
900	-0.013	1067.55	779.06	939.20	739.39	634.40	529.76	
1000	-0.012	1182.57	863.25	1040.56	819.32	703.02	587.09	

HIKROBOT

Hangzhou Hikrobot Co., Ltd.
en.hikrobotics.com

© Hangzhou Hikrobot Co., Ltd. All Rights Reserved.

Hangzhou Hikrobot does not tolerate any infringement. Any organization or individual may not imitate or reproduce in whole or in part of the content. The data herein is based on Hikrobot's internal evaluation. Actual data may vary depending on specific configuration and operating condition. The information herein is subject to change without notice. All the content has been checked conscientiously. Nevertheless, Hikrobot shall not be liable to damages resulting from errors, inconsistencies or omissions.