

The CZ-EMM3 and CZ-EMM4 proximity card readers - also referred to as the „reading heads” - are designed for reading out the code of proximity cards, token key fobs or other passive transponders in access control systems. They can be used in conjunction with the CA-64 SR proximity card reader expander and the ACCO-KP and ACCO-KP-PS door controller modules, manufactured by the SATEL Company. They are capable of interfacing with other access control devices which receive data in one of the reader supported formats. Design of the readers enables them to be installed outdoors. The CZ-EMM4 reader is fitted with a bell button.

1. Description of the readers

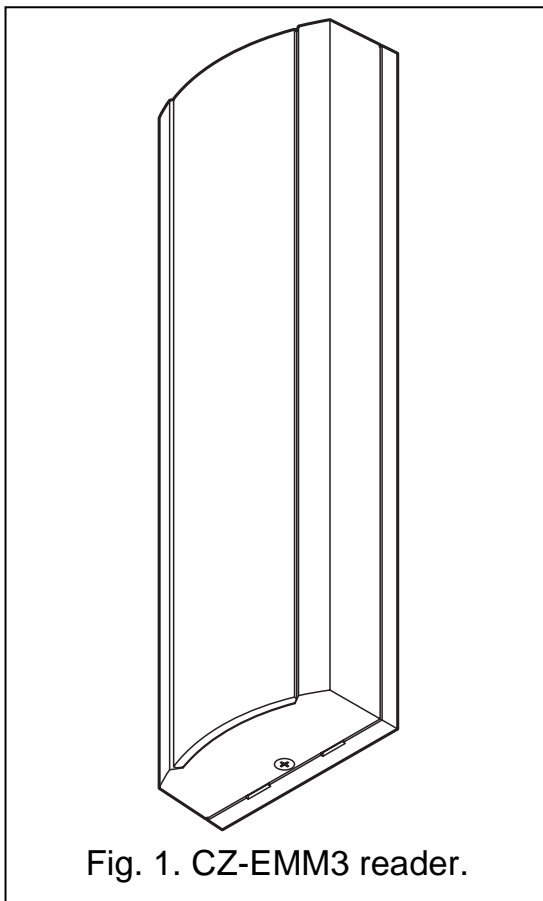

Fig. 1. CZ-EMM3 reader.

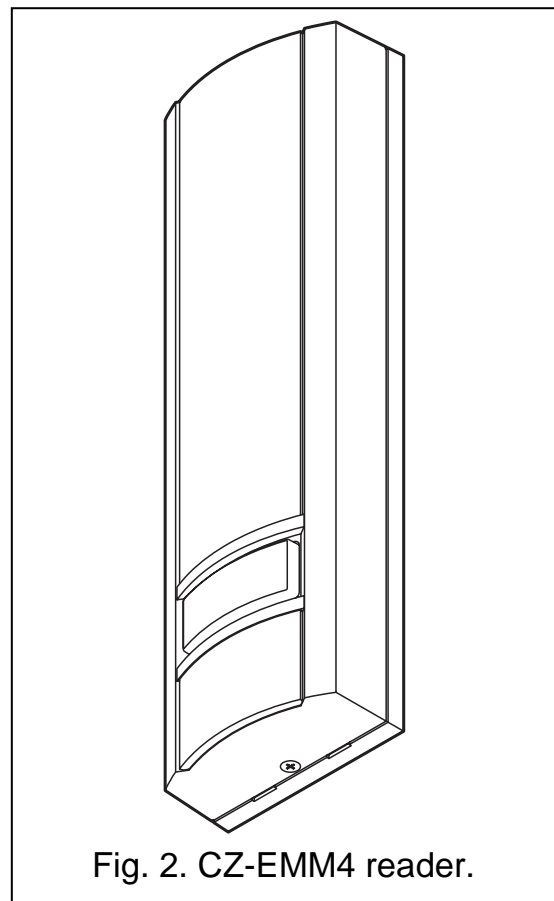

Fig. 2. CZ-EMM4 reader.

The heads can transmit data (i.e. the read-out code) in one of the following formats:

- EM-MARIN (which is used for communication with the devices manufactured by SATEL)
- WIEGAND 26
- CLOCK&DATA

The way of changing the data transmission format is described in section CONFIGURATION OF THE READERS.

The readers have two built-in LED indicators (one red and one green), as well as a buzzer, which serve the signaling purposes. The way of signaling and situations when the signaling is triggered depend on the control device to which the reader is connected. Electronic circuits of the head are coated with epoxy resin to protect them against moisture. A multi-core cable for connecting the reader to the control device is led out from the head housing (see CONNECTION OF THE READERS).

The bell button in the CZ-EMM4 reader controls the OC type low-current output. Push the button to short the output to ground. Violet color wire is soldered to the output.

2. Card readout

The reader supports cards, token key fobs or other 125 kHz passive transponders (UNIQUE, EM4001, EM4002, EM4003, EM4102). For the head to read out the coded number of a card (wherever the „card” is referred to in this manual, it means a passive transponder, which can have the form of a card, key fob, etc.), the card must be moved to a few centimeter distance from the reader for at least 0.5 s. When read out, the card number is sent to a control device (e.g. CA-64 SR expander) which signals (by means of the LEDs / buzzer) completion of the card code read-out and initiates appropriate actions. A next card code can be read immediately after moving the previous card away from the reader. In case of EM-MARIN format transmission, if the card has not have been removed from the reading zone, the card code will be repeatedly read out and sent to the control device. The control device can then take various actions, depending on whether the card has only been brought closer for 0.5 s, or held out for approx. 3 s.

3. Installation



Any electrical connections may only be made when power supply is disconnected.

Remember during installation that the proximity card readers to be installed and the heads connected to other control devices, as well as the LCD keypads and keypads with built-in readers, should be positioned at a distance of at least 50 cm from one another. Two readers connected to the same control device may operate within a close distance between them. The control device will alternately block the heads so as to eliminate the possibility of mutual interference. The signal is passed through the brown cable.

Note: *If the head is mounted on metal surface, the reading range will be reduced.*

3.1 Connection of the readers

The length of the cable connecting the head to the control device should not exceed 30 m. The CZ-EMM3 and CZ-EMM4 readers should be hooked up to the SATEL made modules (CA-64 SR, ACCO-KP, ACCO-KP-PS) in accordance with Table 1. The black cable is not used in this configuration, hence it should not be connected to any terminal. The violet cable (bell) may be connected e.g. to the control panel zone or the door controller module.

Note: *Terminals designated TMPA and TMPB are mounted on the electronics boards of the CA-64 SR expander in version 1.6 or later. If you want to connect the reader to an older version of the expander (1.5 or earlier), you*

should disable the HEAD CONTROL option in the expander settings. The white cable of the expander can be either left unconnected or connected to common ground. Alternatively, you can connect the cable directly to the control panel so that the head presence can be checked. The cable is shorted to common ground in the head via a 2.2 kΩ resistor. The zone to which the cable is to be connected in the control panel should be programmed as 24H TAMPER and the line type is to be selected accordingly.











Cable color	Function	Module terminals		Designation for WIEGAND 26 / CLOCK&DATA formats
		Head A	Head B	
 red	head power supply	+GA	+GB	+12V
 blue	common ground	COM	COM	COM
 green	data (0)	SIGA	SIGB	OUT0 / DATA
 black	data (1)	<i>do not connect</i>		OUT1 / CLOCK
 yellow	buzzer control	BPA	BPB	BEEP
 pink	green LED control	LD1A	LD1B	LED-G
 gray	red LED control	LD2A	LD2B	LED-R
 brown	blocking head operation	DISA	DISB	HOLD
 white	presence control	TMPA	TMPB	TMP
 violet	bell (CZ-EMM4 only)	<i>do not connect</i>		BELL

Table 1. Description of cables and connection of reader cables to terminals of SATEL manufactured modules.

3.2 Configuration of the readers

The reader with factory settings transmits data in the EM-MARIN format to the control device, and its inputs (buzzer and LEDs control, head operation blocking) are activated by the high status (applying 5...12V voltage). In this state, the reader is ready for interfacing with the modules manufactured by SATEL. In order to change the reader settings, proceed as follows:

1. Turn off power supply of the control device.
2. Disconnect all the reader cables from the control device.
3. Connect the red and blue cables of the reader (i.e. the supply cables) to the control device.
4. If the reader inputs are to be activated by the low status (0V), connect the pink cable of the reader to the common ground terminal of the control device. If the reader inputs are to be activated by the high status (5...12V), the pink cable is to be left unconnected.
5. Connect the brown and green cables together.
6. Turn on power supply of the control device. The reader will signal entry into the programming mode with 4 short and 1 long beeps. The selected polarization of inputs (high/low status control) will be set automatically on power-up. The reader LEDs will display information on the currently selected format of data transfer to the control device:
 - red color LED blinking fast – EM-MARIN format

- green color LED blinking fast – WIEGAND 26 format
 - both LEDs blinking fast – CLOCK&DATA format
7. Hold out a proximity card to the reader in order to change the data transfer format. Holding the card out will each time change the format, which will be accordingly signaled by the LEDs.
 8. Having selected the appropriate format, switch off the control device. The format will be saved automatically, confirmation of the selection being unnecessary.
 9. Connect all the reader cables to the control device. The reader is ready now for operation with its new settings.

4. Technical data

Rated supply voltage	12 V DC \pm 15%
Maximum current consumption	80 mA
Housing dimensions	47 x 158 x 24 mm
Working temperature range.....	-20...+55 °C
Working humidity range.....	0...95%
Current-carrying capacity, BELL output	30 mA
Head operating frequency	125 kHz
Data transmission standard.....	EM-MARIN / WIEGAND 26 / CLOCK&DATA
Weight: CZ-EMM3	315 g
CZ-EMM4	287 g

The latest EC declaration of conformity and certificates are available for downloading on our website www.satel.pl



SATEL sp. z o.o.
 ul. Schuberta 79
 80-172 Gdańsk
 POLAND
 tel. + 48 58 320 94 00
 info@satel.pl
 www.satel.pl