

# MV-CH089-10GM/GC

## 8.9 MP 1" CMOS GigE Area Scan Camera



GEN<i>i</i>CAM

GigE VISION

### Introduction

MV-CH089-10GM/GC camera adopts Sony® IMX267 sensor to provide high-quality image. It uses GigE interface to transmit non-compressed images in real time with max. frame rate reaching 13.7 fps.

### Key Feature

- Supports LSC, Sequencer, passive transmission, etc.
- Color camera supports Super Bayer, Super Palette, etc.
- Compact design with mounting holes on panels for flexible mounting from 4 sides.
- Adopts GigE interface and max. transmission distance of 100 meters without relay.
- Supports hardware trigger, software trigger, free run, etc.
- Compatible with GigE Vision Protocol V2.0, GenICam Standard, and third-party software based on these protocol and standard.

### Dimension

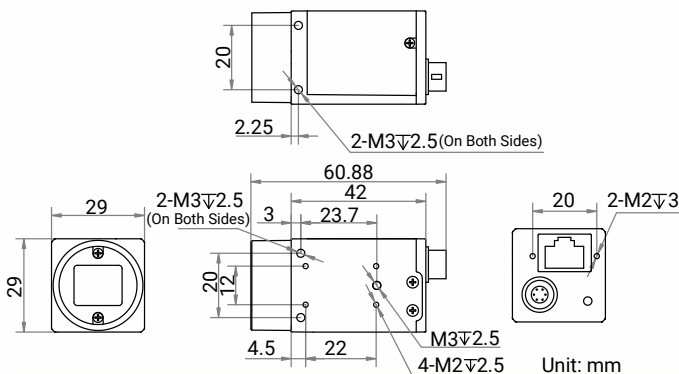

### Available Model

- Mono camera: MV-CH089-10GM
- Color camera: MV-CH089-10GC

### Applicable Industry

Electronic semiconductor, factory automation, logistics code reading, medicine packaging, etc.

### Sensor Quantum Efficiency

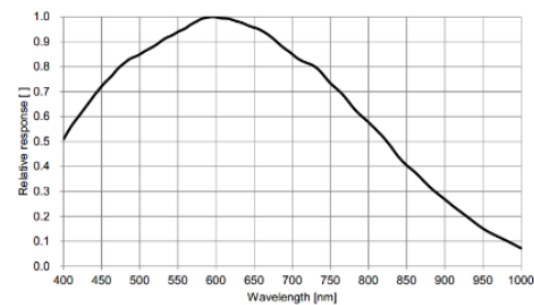

MV-CH089-10GM

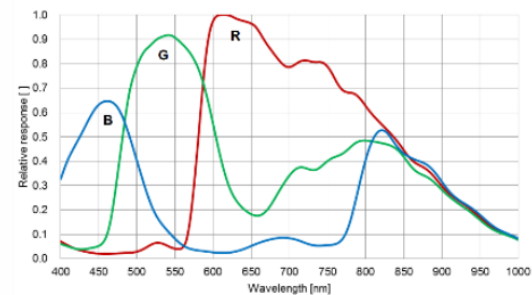

MV-CH089-10GC



# Specification

Model	MV-CH089-10GM	MV-CH089-10GC
<b>Performance</b>		
Sensor type	CMOS, global shutter	
Sensor model	Sony® IMX267	
Pixel size	3.45 μm × 3.45 μm	
Sensor size	1"	
Resolution	4096 × 2160	
Max. frame rate	13.7 fps @4096 × 2160 Mono 8	13.7 fps @4096 × 2160 Bayer RG 8
Dynamic range	70.8 dB	
SNR	39.8 dB	
Gain	0 dB to 24 dB	
Exposure time	UltraShort exposure mode: 1 μs to 14 μs	
	Standard exposure mode: 15 μs to 10 sec	
Exposure mode	Off/Once/Continuous exposure mode	
Mono/color	Mono	Color
Pixel format	Mono 8/10/10Packed/12/12Packed	Mono 8/10/12, Bayer RG 8/10/10Packed/12/12Packed, YUV422Packed, YUV422_YUYV_Packed, RGB 8, BGR 8
Binning	Supports 1 × 1, 2 × 2, 4 × 4	
Decimation	Supports 1 × 1, 2 × 2, 4 × 4	
Reverse image	Supports horizontal and vertical reverse image output	
<b>Electrical features</b>		
Data interface	Gigabit Ethernet, compatible with Fast Ethernet	
Digital I/O	6-pin P7 connector provides power and I/O, including opto-isolated input × 1 (Line 0), optoisolated output × 1 (Line 1), and bi-directional non-isolated I/O × 1 (Line 2).	
Power supply	9 VDC to 24 VDC, supports PoE	
Power consumption	Typ. 2.3 W@12 VDC	Typ. 2.4 W@12 VDC
<b>Mechanical</b>		
Lens mount	C-mount	
Dimension	29 mm × 29 mm × 42 mm (1.1" × 1.1" × 1.7")	
Weight	Approx. 100 g (0.2 lb.)	
Ingress protection	IP40 (under proper lens installation and wiring)	
Temperature	Working temperature: -10 °C to 50 °C (14 °F to 122 °F)	
	Storage temperature: -30 °C to 70 °C (-22 °F to 158 °F)	
Humidity	20% to 95% RH, non-condensing	
<b>General</b>		
Client software	MVS or third-party software meeting with GigE Vision Protocol	
Operating system	32/64-bit Windows XP/7/10, 32/64-bit Linux and 64-bit MacOS	
Compatibility	GigE Vision V2.0, GenICam	
Certification	CE, RoHS, KC	

## HIKROBOT

Hangzhou Hikrobot Co., Ltd.  
en.hikrobotics.com

© Hangzhou Hikrobot Co., Ltd. All Rights Reserved.  
Hangzhou Hikrobot does not tolerate any infringement. Any organization or individual may not imitate or reproduce in whole or in part of the content. The data herein is based on Hikrobot's internal evaluation. Actual data may vary depending on specific configuration and operating condition. The information herein is subject to change without notice. All the content has been checked conscientiously. Nevertheless, Hikrobot shall not be liable to damages resulting from errors, inconsistencies or omissions.