

MV-CL042-91GM

4096 P CMOS GigE Line Scan Camera



GEN*i*CAM

GigE
VISION

Introduction

MV-CL042-91GM camera adopts CMOS sensor to provide high-quality image and integrates multiple ISP image algorithms and functions. It supports several external trigger modes such as line trigger, frame trigger, and line + frame trigger, etc. It uses GigE interface to transmit images in real time and its max. line rate can reach 80 kHz in the high-bandwidth mode.

Key Feature

- Supports image high-bandwidth mode, TDI, trigger-width exposure, etc.
- Supports manual adjustment for Gamma correction, PRNU correction, LUT, black level offset, etc.
- Adopts bi-directional I/O connection, flexible configuration for Input/Output.
- Compact design and flexible installation.
- Compatible with GigE Vision V2.0 and GenICam standard.

Available Model

MV-CL042-91GM

Applicable Industry

Printing, textiles, railway, logistics, metallurgy, food, pharmaceutical manufacturing, material sorting, etc.

Sensor Quantum Efficiency

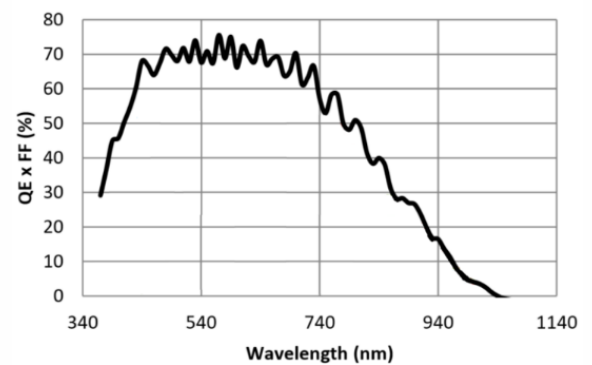

Dimension

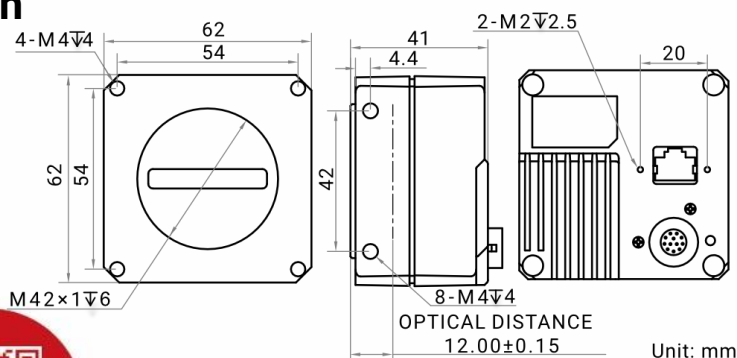

Specification

Model	MV-CL042-91GM
Camera	
Sensor type	CMOS
Pixel size	7 μm
Resolution	4096 \times 2
Image mode	Supports 1 Line/2 TDI
Max. line rate*	Standard mode: 28 kHz @Mono 8, 14 kHz @Mono 10/12 High-bandwidth mode: 80 kHz @Mono 8/10/12
Dynamic range	65.6 dB
SNR	40 dB
Gain	Supports 1.0 \times , 1.4 \times , 1.6 \times , 2.4 \times , 3.2 \times
Exposure time	5 μs to 10 ms
Exposure mode	Off/ Once/ Continuous exposure mode, and supports trigger-width exposure
Mono/color	Mono
Pixel format	Mono 8/10/12
Binning	Supports 1 \times 1, 1 \times 2, 1 \times 4, 2 \times 1, 2 \times 2, 2 \times 4, 4 \times 1, 4 \times 2, 4 \times 4
Reverse image	Supports horizontal reverse image output
Trigger mode	External trigger, internal trigger
External trigger mode	Line trigger, frame trigger, line + frame trigger
Electrical feature	
Data interface	Gigabit Ethernet, compatible with Fast Ethernet
Digital I/O	12-pin Hirose connector provides power and I/O: configurable output and input \times 4 (Line 0/1/3/4), supports single-end/differential
Power supply	12 VDC to 24 VDC, supports PoE
Power consumption	Typ. 5.8 W@12 VDC
Mechanical	
Lens mount	M42 *1.0, optical back focal length: 12 mm (0.5"), applicable to F/C-mount and others via adapter
Dimension	62 mm \times 62 mm \times 41 mm (2.4" \times 2.4" \times 1.6")
Weight	Approx. 280 g (0.6 lb.)
Ingress protection	IP40 (under proper lens installation and wiring)
Temperature	Working temperature: -20 $^{\circ}\text{C}$ to 55 $^{\circ}\text{C}$ (-4 $^{\circ}\text{F}$ to 131 $^{\circ}\text{F}$) Storage temperature: -30 $^{\circ}\text{C}$ to 80 $^{\circ}\text{C}$ (-22 $^{\circ}\text{F}$ to 176 $^{\circ}\text{F}$)
Humidity	5% to 90% RH, non-condensing
General	
Client software	MVS or the third-party software meeting with GigE Vision protocol
Operating system	32/64-bit Windows XP/7/10, 32/64-bit Linux, and 64-bit MacOS
Compatibility	GigE Vision V2.0, GenICam
Certification	CE, RoHS, KC

*The actual line rate after enabling high-bandwidth mode depends on images of objects, and max. line rate in high-bandwidth mode is for reference only.

HIKROBOT

Hangzhou Hikrobot Co., Ltd.
en.hikrobotics.com

© Hangzhou Hikrobot Co., Ltd. All Rights Reserved.

Hangzhou Hikrobot does not tolerate any infringement. Any organization or individual may not imitate or reproduce in whole or in part of the content. The data herein is based on Hikrobot's internal evaluation. Actual data may vary depending on specific configuration and operating condition. The information herein is subject to change without notice. All the content has been checked conscientiously. Nevertheless, Hikrobot shall not be liable to damages resulting from errors, inconsistencies or omissions.