

# MV-CL082-92CM

8192 P Camera Link Line Scan Camera



GEN*i*CAM



## Introduction

MV-CL082-92CM camera adopts CMOS sensor to provide high quality images and uses Camera Link interface to transmit images in real time, and its max. line rate reaches 100 kHz in full resolution. It adopts multiple ISP technologies, and supports external trigger modes like line trigger, frame trigger, and trigger-width exposure.

## Key Feature

- Supports multiple exposure and image acquisition modes.
- Adopts multiple ISP technologies and supports manual adjustment for Gamma correction, FFC correction, LUT, black level, etc.
- Supports ROI to increase line rate (max. 200 kHz in 1-line mode).
- Supports bi-directional I/O wiring for flexible input/output settings.
- Compact design and flexible installation.
- Compatible with Camera Link Protocol and GenICam Standard.

## Available Model

MV-CL082-92CM

## Applicable Industry

New energy, screen detection, consumer electronics, PCB, metallurgy.

## Sensor Quantum Efficiency

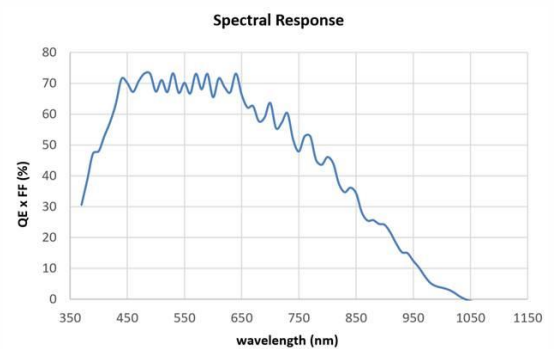

## Dimension

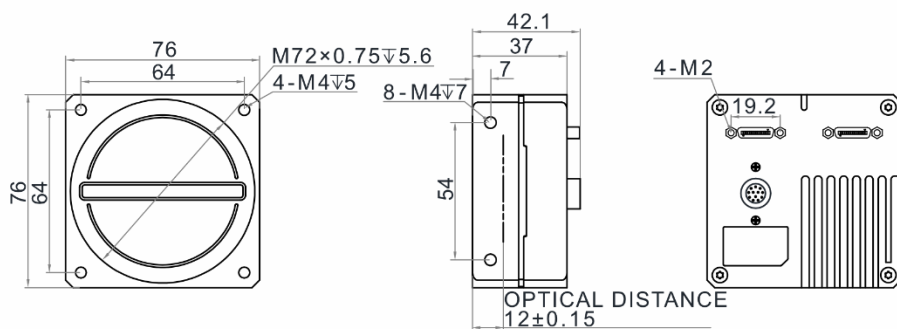

Unit: mm



# Specification

<b>Model</b>	<b>MV-CL082-92CM</b>
<b>Camera</b>	
<b>Sensor type</b>	CMOS
<b>Pixel size</b>	7 $\mu$ m
<b>Resolution</b>	8192 $\times$ 2
<b>Image mode</b>	Supports 1-line, 2-TDI
<b>Max. line rate</b>	20 kHz (Base), 40 kHz (Medium), 80 kHz (Full), 100 kHz (80-bit)
<b>Configuration mode</b>	Base, Medium, Full, 80-bit
<b>Tap geometry</b>	1 $\times$ 2, 1 $\times$ 4, 1 $\times$ 8, 1 $\times$ 10
<b>Tap number</b>	2 Taps, 4 Taps, 8 Taps, 10 Taps
<b>Pixel clock</b>	40 MHz, 66 MHz, 80 MHz, 85 MHz
<b>Dynamic range</b>	63.4 dB
<b>SNR</b>	40.8 dB
<b>Gain</b>	Supports 1.0 $\times$
<b>Exposure time</b>	3 $\mu$ s to 10 ms
<b>Exposure mode</b>	Off/ Once/ Continuous exposure mode; supports fixed time exposure, trigger-width exposure
<b>Mono/color</b>	Mono
<b>Pixel format</b>	Mono 8/10/12
<b>Binning</b>	Supports 1 $\times$ 1, 2 $\times$ 2, 4 $\times$ 4
<b>Reverse image</b>	Supports horizontal reverse image output
<b>Trigger mode</b>	External trigger, internal trigger
<b>External trigger mode</b>	Line trigger, frame trigger, line + frame trigger
<b>Electrical features</b>	
<b>Data interface</b>	Camera Link (SDR connector); USB interface for updating firmware
<b>Digital I/O</b>	12-pin P10 connector provides power and I/O: configurable input/output $\times$ 4 (Line 0/1/3/4) and support single-ended/differential. Camera Link provides I/O (CC1/CC2/CC3/CC4).
<b>Power supply</b>	12 VDC to 24 VDC
<b>Power consumption</b>	Typ. 9.8 W@12 VDC
<b>Mechanical</b>	
<b>Lens mount</b>	M72*0.75, optical back focal length: 12 mm (0.5"), applicable to F-mount via lens adapter
<b>Dimension</b>	76 mm $\times$ 76 mm $\times$ 42.1 mm (3.0" $\times$ 3.0" $\times$ 1.7")
<b>Weight</b>	Approx. 320 g (0.7 lb.)
<b>Ingress protection</b>	IP40 (under proper lens installation and wiring)
<b>Temperature</b>	Working temperature: -20 $^{\circ}$ C to 55 $^{\circ}$ C (-4 $^{\circ}$ F to 131 $^{\circ}$ F) Storage temperature : -30 $^{\circ}$ C to 80 $^{\circ}$ C (-22 $^{\circ}$ F to 176 $^{\circ}$ F)
<b>Humidity</b>	5% to 90% RH, non-condensing
<b>General</b>	
<b>Client software</b>	MVS and frame grabber software meeting with Camera Link Protocol
<b>Operating system</b>	32/64-bit Windows 7/10
<b>Compatibility</b>	Camera Link V1.2, GenICam
<b>Certification</b>	CE, RoHS2.0, KC

## HIKROBOT

Hangzhou Hikrobot Co., Ltd.  
en.hikrobotics.com

© Hangzhou Hikrobot Co., Ltd. All Rights Reserved.

Hangzhou Hikrobot does not tolerate any infringement. Any organization or individual may not imitate or reproduce in whole or in part of the content. The data herein is based on Hikrobot's internal evaluation. Actual data may vary depending on specific configuration and operating condition. The information herein is subject to change without notice. All the content has been checked conscientiously. Nevertheless, Hikrobot shall not be liable to damages resulting from errors, inconsistencies or omissions.