

# MV-CL086-91CC

8192 P Camera Link Line Scan Camera



GEN*i*CAM



## Introduction

MV-CL086-91CC camera uses Camera Link interface to transmit images, and its max. line rate can reach 33.7 kHz. It supports RGB true color, TDI, and ISP image signal processing technology. It is applicable to new energy, consumer electronics, PCB, printing, and other industries.

## Key Feature

- Supports configuration modes of Base, Medium and 80-bit via the Camera Link interface.
- Supports TDI function to select different image modes.
- Supports exposure time and gain adjustment, PRNUC correction, LUT, Gamma correction, etc.
- Adopts compact design and supports flexible installation.
- Compatible with Camera Link Protocol and GenICam Standard.

## Dimension

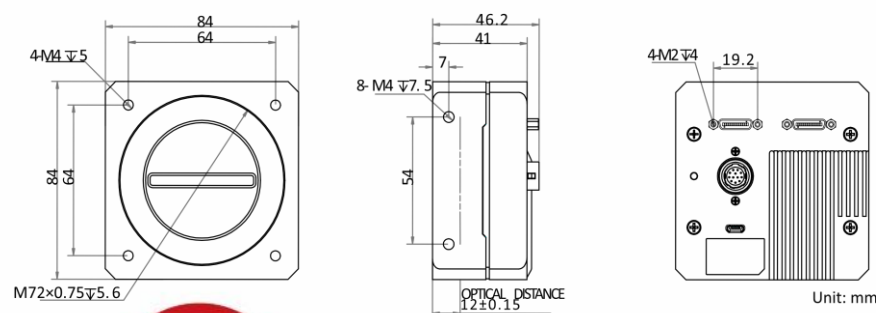

## Available Model

MV-CL086-91CC

## Applicable Industry

New energy, consumer electronics, PCB, printing, etc.

## Sensor Quantum Efficiency

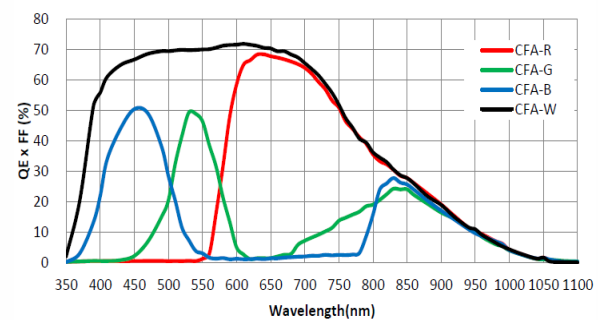

# Specification

<b>Model</b>	<b>MV-CL086-91CC</b>
<b>Camera</b>	
<b>Sensor type</b>	CMOS
<b>Pixel size</b>	5 $\mu\text{m}$
<b>Resolution</b>	8192 $\times$ 6
<b>Image mode</b>	Supports 1-line, 2-TDI
<b>Max. line rate</b>	10.1 kHz (Base), 20.2 kHz (Medium), 33.7 kHz (80-bit)
<b>Configuration mode</b>	Base, Medium, 80-bit
<b>Tap geometry</b>	1 $\times$ 1, 1 $\times$ 2, 1 $\times$ 10
<b>Tap number</b>	1 Tap, 2 Taps, 10 Taps
<b>Pixel clock</b>	40 MHz, 66 MHz, 80 MHz, 85 MHz
<b>Dynamic range</b>	62 dB
<b>SNR</b>	40 dB
<b>Gain</b>	Supports 1.2 $\times$ , 2.7 $\times$ , 3.0 $\times$ , 3.5 $\times$ , 4.6 $\times$ , 6.2 $\times$
<b>Exposure time</b>	3 $\mu\text{s}$ to 10 ms
<b>Exposure mode</b>	Off/ Once/ Continuous exposure mode; supports fixed exposure time, trigger-width exposure
<b>Mono/color</b>	Color
<b>Pixel format</b>	RGB 8, BGR 8, Mono 8
<b>Binning</b>	Supports 1 $\times$ 1, 2 $\times$ 2, 4 $\times$ 4
<b>Reverse image</b>	Supports horizontal reverse image output
<b>Trigger mode</b>	External trigger, internal trigger
<b>External trigger mode</b>	Line trigger, frame trigger, line + frame trigger
<b>Electrical features</b>	
<b>Data interface</b>	Camera Link (SDR connector); USB interface for updating firmware
<b>Digital I/O</b>	12-pin P10 connector provides power and I/O: configurable input and output $\times$ 4 (Line 0/1/3/4), and support single-end/differential. Camera Link provides I/O (CC1/CC2/CC3/CC4).
<b>Power supply</b>	12 VDC to 24 VDC
<b>Power consumption</b>	Typ. 9.6 W@12 VDC
<b>Mechanical</b>	
<b>Lens mount</b>	M72*0.75, optical back focal length: 12 mm (0.5"), applicable to F-mount via lens adapter
<b>Dimension</b>	84 mm $\times$ 84 mm $\times$ 46.2 mm (3.3" $\times$ 3.3" $\times$ 1.8")
<b>Weight</b>	Approx. 476 g (1.0 lb.)
<b>Ingress protection</b>	IP40 (under proper lens installation and wiring)
<b>Temperature</b>	Working temperature: -20 $^{\circ}\text{C}$ to 55 $^{\circ}\text{C}$ (-4 $^{\circ}\text{F}$ to 131 $^{\circ}\text{F}$ ) Storage temperature: -30 $^{\circ}\text{C}$ to 80 $^{\circ}\text{C}$ (-22 $^{\circ}\text{F}$ to 176 $^{\circ}\text{F}$ )
<b>Humidity</b>	5% to 90% RH, non-condensing
<b>General</b>	
<b>Client software</b>	MVS and frame grabber software meeting with Camera Link Protocol
<b>Operating system</b>	32/64-bit Windows 7/10
<b>Compatibility</b>	Camera Link V1.2, GenICam
<b>Certification</b>	CE, FCC, RoHS2.0, KC

**HIKROBOT**

Hangzhou Hikrobot Co., Ltd.  
en.hikrobotics.com

© Hangzhou Hikrobot Co., Ltd. All Rights Reserved.

Hangzhou Hikrobot does not tolerate any infringement. Any organization or individual may not imitate or reproduce in whole or in part of the content. The data herein is based on Hikrobot's internal evaluation. Actual data may vary depending on specific configuration and operating condition. The information herein is subject to change without notice. All the content has been checked conscientiously. Nevertheless, Hikrobot shall not be liable to damages resulting from errors, inconsistencies or omissions.