

MV-CU050-60GM

5 MP 1/2.5" CMOS GigE Area Scan Camera



GEN<i>i>CAM

GigE VISION

Introduction

MV-CU050-60GM camera adopts CMOS sensor to provide high-quality images. It uses GigE interface to transmit non-compressed images in real time, and its max. frame rate can reach 23.1 fps in full resolution.

Key Feature

- Adopts low power consumption design with stable performance.
- Supports auto and manual adjustment of gain, exposure time, etc.
- Supports hardware trigger, software trigger, free run, etc.
- Adopts GigE interface and max. transmission distance of 100 meters without relay.
- Compatible with GigE Vision V2.0 Protocol, GenlCam Standard, and third-party software based on the protocol and standard.

Available Model

MV-CU050-60GM

Applicable Industry

Electronics and semiconductor, factory automation, logistics and code reading, medicine package, etc.

Sensor Quantum Efficiency

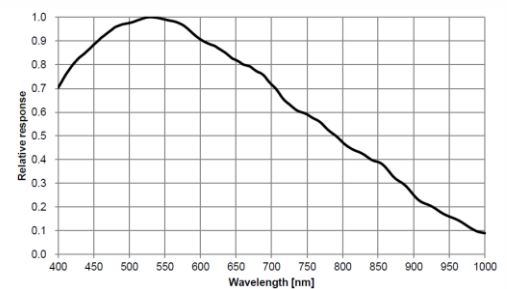

Dimension

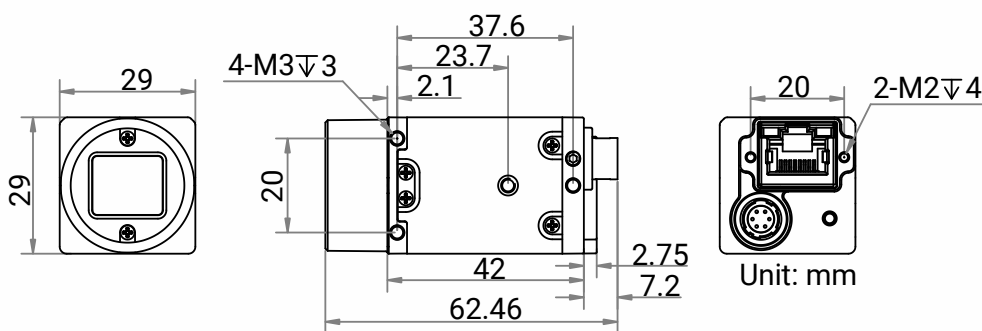

Specification

Model	MV-CU050-60GM
Performance	
Sensor type	CMOS, rolling shutter
Pixel size	2.2 μm \times 2.2 μm
Sensor size	1/2.5"
Resolution	2592 \times 1944
Max. frame rate	23.1 fps @2592 \times 1944 Mono 8
Dynamic range	70.2 dB
SNR	40.8 dB
Gain	0 dB to 24 dB
Exposure time	24 μs to 2.5 sec
Exposure mode	Off/Once/Continuous exposure mode
Mono/color	Mono
Pixel format	Mono 8/10/10Packed/12/12Packed
Binning	Supports 1 \times 1, 2 \times 2
Decimation	Supports 1 \times 1, 2 \times 2, 4 \times 4
Reverse image	Supports horizontal and vertical reverse image output
Electrical features	
Data interface	Gigabit Ethernet, compatible with Fast Ethernet
Digital I/O	6-pin P7 connector provides power and I/O, including opto-isolated input \times 1 (Line 0), opto-isolated output \times 1 (Line 1), bi-directional non-isolated I/O \times 1 (Line 2).
Power supply	9 VDC to 24 VDC, PoE is optional
Power consumption	Typ. 2.5 W@12 VDC
Mechanical	
Lens mount	C-mount
Dimension	29 mm \times 29 mm \times 42 mm (1.1" \times 1.1" \times 1.7")
Weight	Approx. 100 g (0.2 lb.)
Ingress protection	IP30 (under proper lens installation and wiring)
Temperature	Working temperature: 0 $^{\circ}\text{C}$ to 50 $^{\circ}\text{C}$ (32 $^{\circ}\text{F}$ to 122 $^{\circ}\text{F}$) Storage temperature: -30 $^{\circ}\text{C}$ to 70 $^{\circ}\text{C}$ (-22 $^{\circ}\text{F}$ to 158 $^{\circ}\text{F}$)
Humidity	20% to 95% RH, non-condensing
General	
Client software	MVS or third-party software meeting with GigE Vision Protocol
Operating system	32/64-bit Windows XP/7/10, 32/64-bit Linux and 64-bit MacOS
Compatibility	GigE Vision V2.0, GenICam
Certification	CE, RoHS, KC

HIKROBOT

Hangzhou Hikrobot Co., Ltd.
en.hikrobotics.com

© Hangzhou Hikrobot Co., Ltd. All Rights Reserved.

Hangzhou Hikrobot does not tolerate any infringement. Any organization or individual may not imitate or reproduce in whole or in part of the content. The data herein is based on Hikrobot's internal evaluation. Actual data may vary depending on specific configuration and operating condition. The information herein is subject to change without notice. All the content has been checked conscientiously. Nevertheless, Hikrobot shall not be liable to damages resulting from errors, inconsistencies or omissions.