

# MV-VC350\*H

## VC3000 Series Vision Controller



### Introduction

MV-VC350\*H vision controller adopts Intel® i5-8500 CPU, and supports 8 GB or 16 GB memory. It supports 24-channel GPIO, and has multiple interfaces, such as, GigE, USB 2.0, and USB 3.0.

### Key Feature

- Adopts 8<sup>th</sup> generation Intel® CPU to offer strong performance.
- Provides extended slot to connect with image frame grabbers.
- Supports 24-channel GPIO and NPN/PNP switching for output.
- Adopts GigE interfaces for stable data transmission.
- Supports PCIe 3.0 ×16 interface.
- Built-in USB interface for on-site maintenance is optional.

### Available Model

- MV-VC3501H-128G60 (128 GB SSD)
- MV-VC3502H-128G60 (128 GB SSD + 2 TB HDD)
- MV-VC3503H-128G60 (128 GB SSD + 2 TB HDD, PoE supported)
- MV-VC3504H-128G60 (128 GB SSD + 2 TB HDD, 16 GB memory)

### Applicable Industry

Consumer electronics, transportation, food and pharmaceutical, etc.

### Dimension

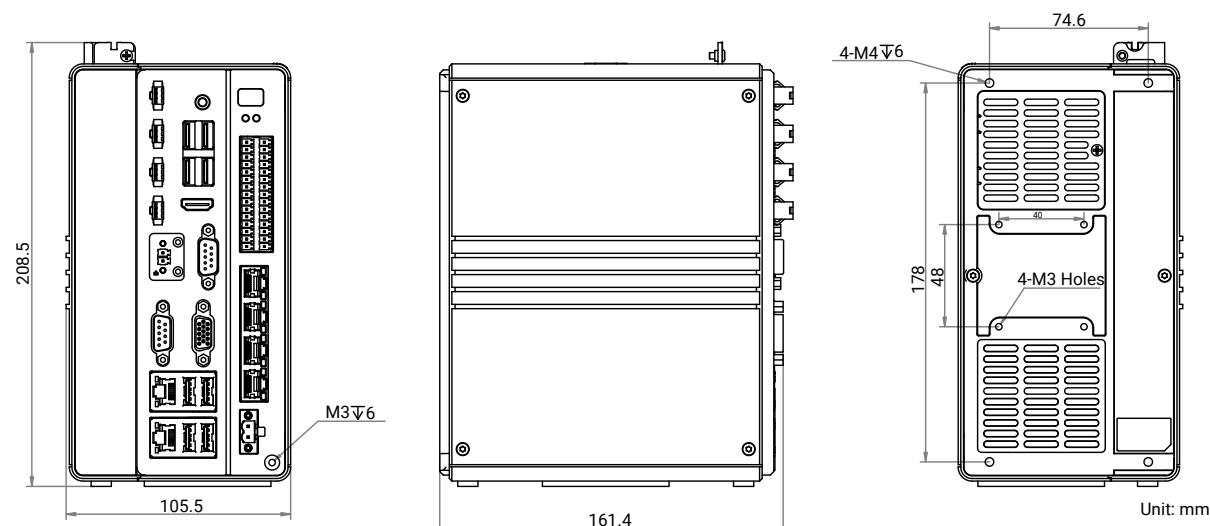

# Specification

**HIKROBOT**

Model	MV-VC3501H-128G60	MV-VC3502H-128G60	MV-VC3503H-128G60	MV-VC3504H-128G60
<b>Performance</b>				
CPU	Intel® Core™ i5-8500			
Memory	8 GB			16 GB
Storage	128 GB SSD, mSATA interface × 1, SATA interface × 1	128 GB SSD + 2 TB HDD, mSATA interface × 1		
GPU	Intel® HD Graphics 630			
Operating system	Unactivated 64-bit Windows 10			
<b>External interface</b>				
Video output	HDMI interface × 1, VGA interface × 1 Supports dual display outputs, max. resolution 1920 × 1080 @60 Hz			
Digital I/O	Opto-isolated input × 8, opto-isolated output × 16 Output supports NPN/PNP switch			
Network interface	GigE interface × 6	GigE interface × 2, GigE interface with PoE × 4		GigE interface × 6
USB interface	USB 2.0 × 4, USB 3.0 × 4, built-in USB 2.0 × 1			
Serial port	RS-232 × 2, supports switching to RS-485 and RS-422			
Light interface	24 VDC constant voltage × 4 (Max. power consumption of single channel is 72 W, total max. power consumption 80 W.)			
Extended interface	PCIe 3.0 × 16 ( × 1)			
<b>Electrical feature</b>				
Power supply	24 VDC			
Power consumption	Typ. 95 W		Typ. 150 W	Typ. 95 W
<b>Mechanical</b>				
Dimension	161.4 mm × 208.5 mm × 105.5 mm (6.4" × 8.2" × 4.2")			
Weight	Approx. 2.1 kg (4.6 lb.)			
Temperature	0 °C to 50 °C (32 °F to 122 °F)			
Humidity	20% to 95% RH, non-condensing			
<b>General</b>				
Certification	CE, KC			