

# MVL-HF2524M-10MP

## 1/1.8" 25mm 10MP FA LENS

HF-P series FA Lens are optimized for machine vision light sources and sensor, with high resolution, excellent image quality, high transmittance and good stability. Featured with fixed focal length, manual aperture and compact size, it is suitable for machine vision industry applications and ideal for industrial cameras.



### Key Features

- Ultra high resolution and consistency of image clarity
- Bigger aperture, lower distortion and higher relative illumination rate
- Achromatic optical system design, Better imaging performance with color camera
- Excellent vibration resistance performance, optical axis shifting within pixel level
- Good stability at high and low temperature
- Multilayer and broadband coating design, compatible with visible and near-infrared applications

### Distortion

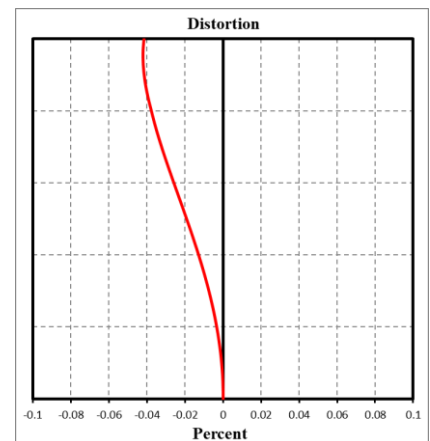

### MTF

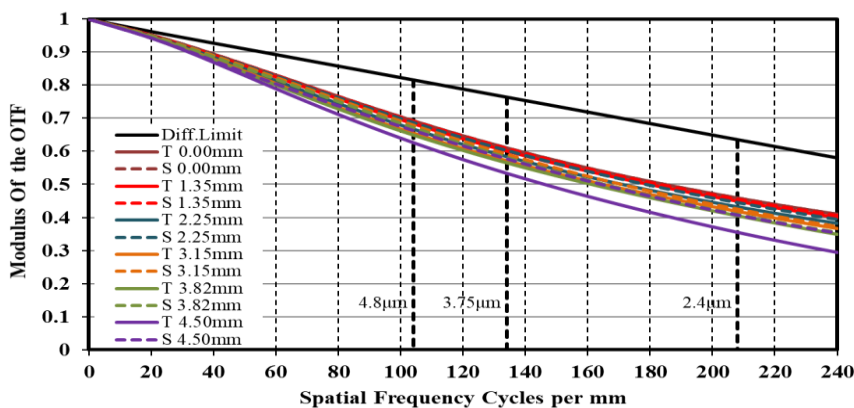

### Relative Illumination

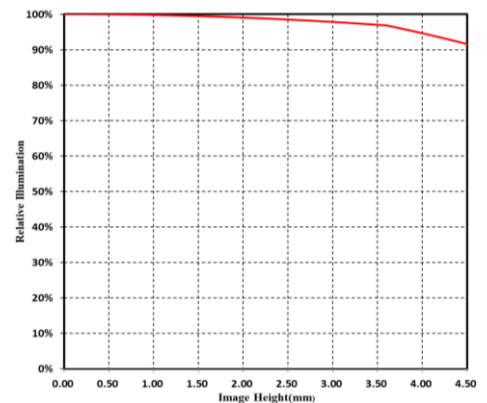

Note: The above curves are the simulate results based on F2.4,  $\beta=-0.051$ , WD=500 mm.



## Specification

Parameter	Model	MVL-HF2524M-10MP
		Fixed focal length, Manual iris, 10MP, FA Lens
<b>Performance</b>		
Focal Length		25 mm
F-Number		F2.4~F16
Image Size		Φ9 mm(1/1.8")
Distortion		-0.01%
Minimum Object Distance		0.1 m
Field of View		D (8.96mm): 19.67° H (7.38mm): 16.19° V (4.92mm): 10.85°
<b>Mechanical</b>		
Iris Control		Manual
Focus Control		Manual
Filter Thread		M27 × 0.5
Mount		C-Mount
Flange Back Length		17.526 mm
Dimension		Φ29 × 41.43 mm
Weight		73.8 g
Temperature		-10 ~ 50°C
<b>General</b>		
Certification		RoHS2.0

## Dimension

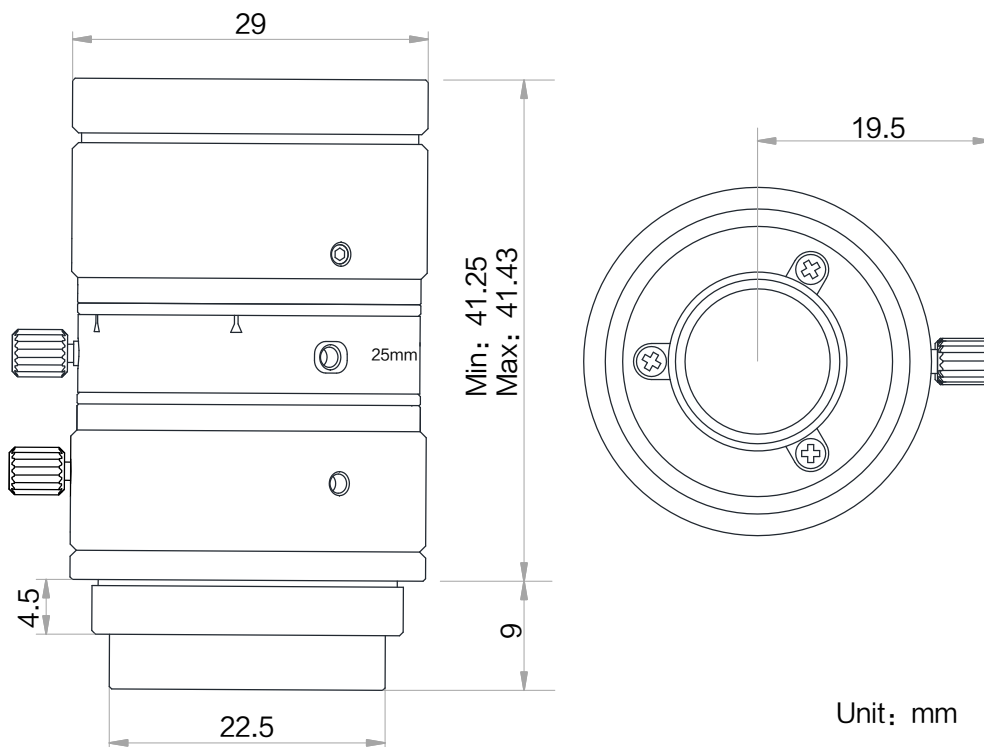

## Field of View

Extension (mm)	Working Distance (mm)		Magnification	Field of View (mm)			
				1/1.8"		1/2"	
				H(7.38mm)	V(4.92mm)	H(6.22mm)	V(4.67mm)
10	near	46.1	-0.655	11.30	7.52	9.52	7.14
	far	65.9	-0.409	18.16	12.08	15.29	11.47
5	near	62.35	-0.470	15.75	10.49	13.27	9.96
	far	125.8	-0.205	36.18	24.08	30.47	22.85
2	near	80.25	-0.358	20.65	13.75	17.39	13.05
	far	305.5	-0.082	90.09	60.02	75.91	56.97
1	near	89	-0.321	23.04	15.35	19.41	14.57
	far	606	-0.041	180.19	120.09	151.85	113.99
0		100	-0.284	26.04	17.35	21.94	16.47
		150	-0.180	41.04	27.35	34.58	25.96
		200	-0.132	56.05	37.35	47.23	35.45
		250	-0.104	71.04	47.34	59.86	44.94
		300	-0.086	86.04	57.34	72.51	54.43
		350	-0.073	101.03	67.33	85.14	63.91
		400	-0.064	116.02	77.33	97.77	73.40
		450	-0.056	131.01	87.32	110.41	82.89
		500	-0.051	146.00	97.32	123.04	92.37
		550	-0.046	160.99	107.31	135.68	101.86
		600	-0.042	175.99	117.31	148.32	111.35
		650	-0.039	190.96	127.29	160.94	120.82
		700	-0.036	205.96	137.30	173.58	130.32
		800	-0.031	235.92	157.27	198.84	149.28
	900	-0.028	265.90	177.26	224.11	168.25	
	1000	-0.025	295.93	197.28	249.42	187.26	

**HIKROBOT**

Hangzhou Hikrobot Co. Ltd.  
en.hikrobotics.com

© Hangzhou Hikrobot Co., Ltd. All Rights Reserved.

Hangzhou Hikrobot does not tolerate any infringement. Any organization or individual may not imitate or reproduce in whole or in part of the content. The data herein is based on Hikrobot's internal evaluation. Actual data may vary depending on specific configuration and operating condition. The information herein is subject to change without notice. All the content has been checked conscientiously. Nevertheless, Hikrobot shall not be liable to damages resulting from errors, inconsistencies or omissions.