

MVL-HF5024M-10MP

1/1.8" 50mm 10MP FA LENS

HF-P series FA Lens are optimized for machine vision light sources and sensor, with high resolution, excellent image quality, high transmittance and good stability. Featured with fixed focal length, manual aperture and compact size, it is suitable for machine vision industry applications and ideal for industrial cameras.



Key Features

- Ultra high resolution and consistency of image clarity
- Bigger aperture, lower distortion and higher relative illumination rate
- Achromatic optical system design, Better imaging performance with color camera
- Excellent vibration resistance performance, optical axis shifting within pixel level
- Good stability at high and low temperature
- Multilayer and broadband coating design, compatible with visible and near-infrared applications

Distortion

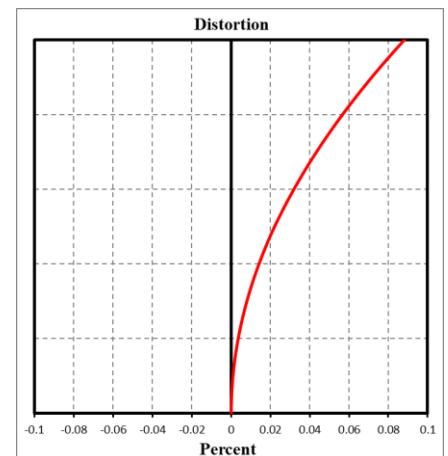

MTF

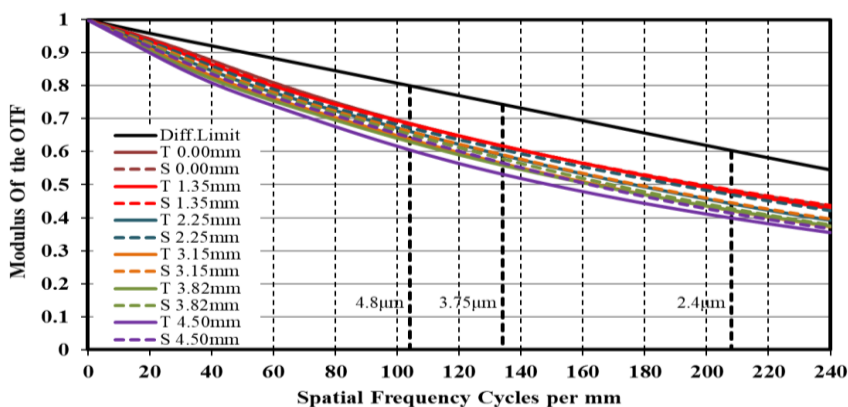

Relative Illumination

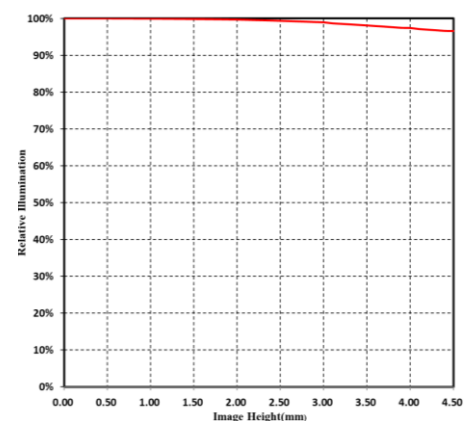

Note: The above curves are the simulate results based on F2.4, $\beta=-0.109$, WD=500 mm.



Specification

Parameter	Model	MVL-HF5024M-10MP
		Fixed focal length, Manual iris, 10MP, FA Lens
Performance		
Focal Length		50 mm
F-Number		F2.4~F16
Image Size		Φ9 mm(1/1.8")
Distortion		0.03%
Minimum Object Distance		0.3 m
Field of View		D (8.96mm): 9.10° H (7.38mm): 7.48° V (4.92mm): 5.00°
Mechanical		
Iris Control		Manual
Focus Control		Manual
Filter Thread		M27 × 0.5
Mount		C-Mount
Flange Back Length		17.526 mm
Dimension		Φ29.5 × 52 mm
Weight		85.9 g
Temperature		-10 ~ 50°C
General		
Certification		RoHS2.0

Dimension

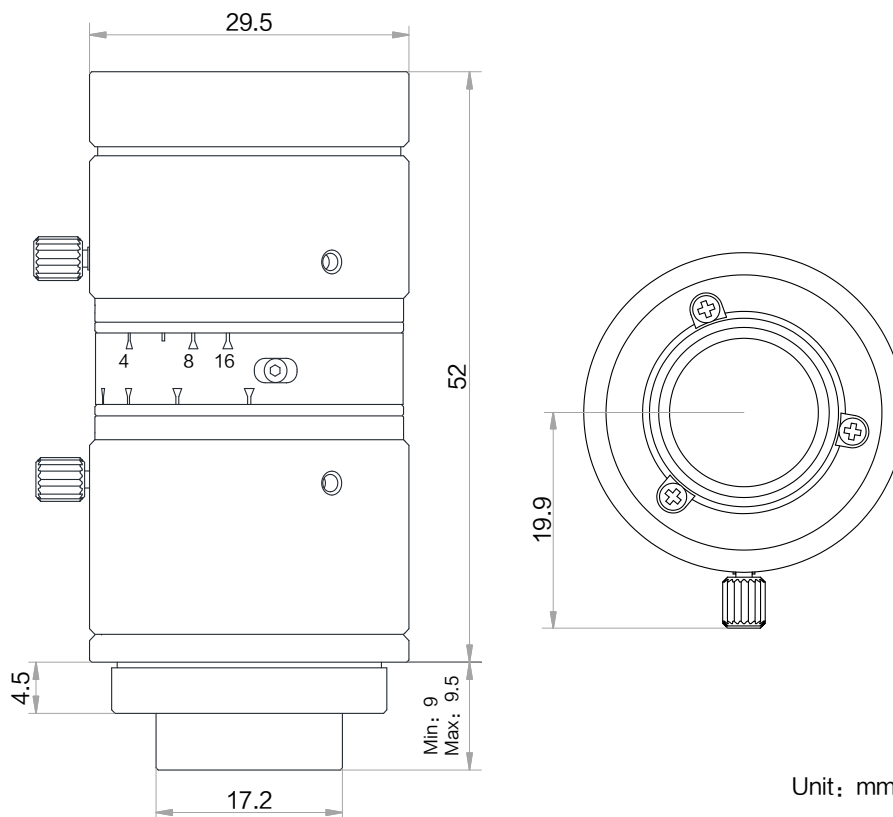

Field of View

Extension (mm)	Working Distance (mm)		Magnification	Field of View (mm)			
				1/1.8"		1/2"	
				H(7.38mm)	V(4.92mm)	H(6.22mm)	V(4.67mm)
10	near	169.4	-0.400	18.49	12.33	15.58	11.70
	far	309	-0.193	38.33	25.55	32.30	24.25
5	near	211.8	-0.296	24.93	16.63	21.02	15.78
	far	578	-0.097	76.35	50.91	64.36	48.32
2	near	255.4	-0.234	31.55	21.04	26.60	19.97
	far	1383	-0.039	190.09	126.76	160.24	120.32
1	near	275.6	-0.213	34.61	23.09	29.18	21.91
	far	2720	-0.019	378.96	252.72	319.46	239.88
0		300	-0.193	38.32	25.56	32.30	24.26
		350	-0.162	45.64	30.44	38.47	28.89
		400	-0.139	52.90	35.28	44.59	33.49
		450	-0.123	60.11	40.09	50.67	38.05
		500	-0.110	67.30	44.88	56.73	42.60
		550	-0.099	74.46	49.65	62.76	47.13
		600	-0.090	81.61	54.42	68.79	51.66
		650	-0.083	88.74	59.18	74.80	56.17
		700	-0.077	95.87	63.93	80.81	60.68
		800	-0.067	110.09	73.42	92.80	69.69
		900	-0.059	124.30	82.89	104.77	78.68
		1000	-0.053	138.47	92.34	116.72	87.65

HIKROBOT

Hangzhou Hikrobot Co. Ltd.
en.hikrobotics.com

© Hangzhou Hikrobot Co., Ltd. All Rights Reserved.
Hangzhou Hikrobot does not tolerate any infringement. Any organization or individual may not imitate or reproduce in whole or in part of the content. The data herein is based on Hikrobot's internal evaluation. Actual data may vary depending on specific configuration and operating condition. The information herein is subject to change without notice. All the content has been checked conscientiously. Nevertheless, Hikrobot shall not be liable to damages resulting from errors, inconsistencies or omissions.