

**MVL-MF0828M-8MP**  
**2/3" 8mm 8MP FA Lens**

MF series FA Lens are optimized for machine vision light sources and sensor, with high resolution, excellent image quality, high transmittance and good stability. Featured with fixed focal length, manual aperture and compact size, it is suitable for machine vision industry applications and ideal for industrial cameras.



**Key Features**

- Ultra-high resolution and consistency of image clarity
- Ultra-low distortion and higher relative illumination
- Achromatic optical system design, better image performance with color camera
- Supports ultra-short working distance with good optical performance
- Compact design, excellent vibration resistance and high and low temperature performance

**Distortion**

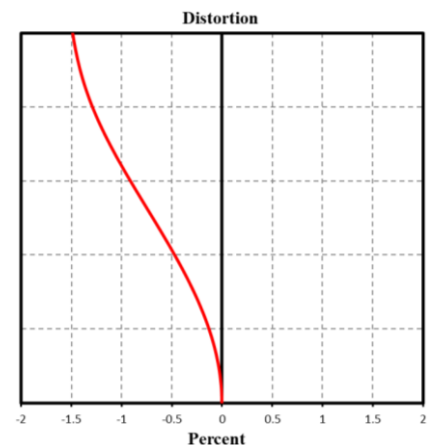

**MTF**

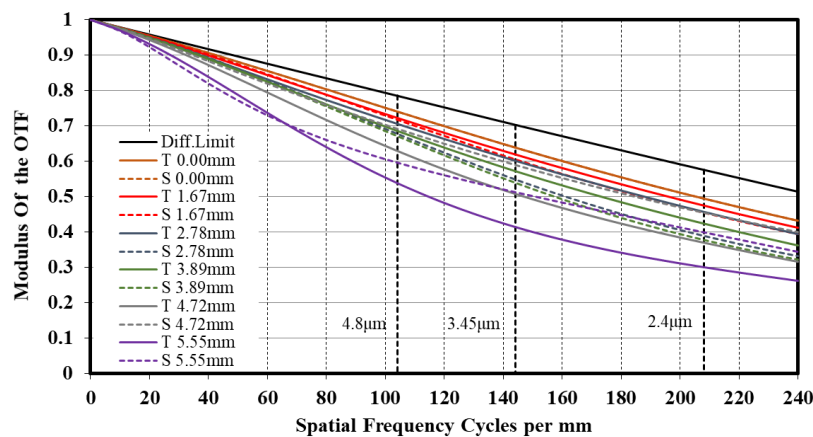

**Relative Illumination**

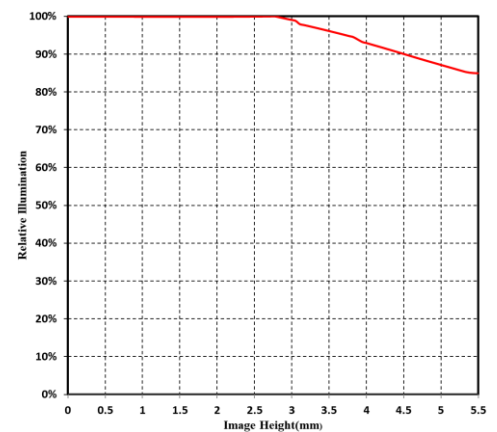

Note: The above curves are the simulate results based on F2.8,  $\beta=-0.03$ , WD=250 mm.



## Specification

Parameter	Model	MVL-MF0828-8MP
		Fixed focal length, Manual iris, 8MP, FA Lens
<b>Performance</b>		
Focal Length		8 mm
F-Number		F2.8 ~ F16
Image Size		Φ11 mm(2/3")
Distortion		0.28%
Minimum Object Distance		0.1 m
Field of View		D (11.1 mm) : 68.46° H (8.45 mm) : 54.97° V (7.07 mm) : 47.06°
<b>Mechanical</b>		
Iris Control		Manual
Focus Control		Manual
Mount		C-Mount
Flange Back Length		17.526 mm
Dimension		Φ35 × 40.27 mm
Weight		80.7 g
Temperature		-10 ~ 50°C
<b>General</b>		
Certification		RoHS2.0

## Dimension

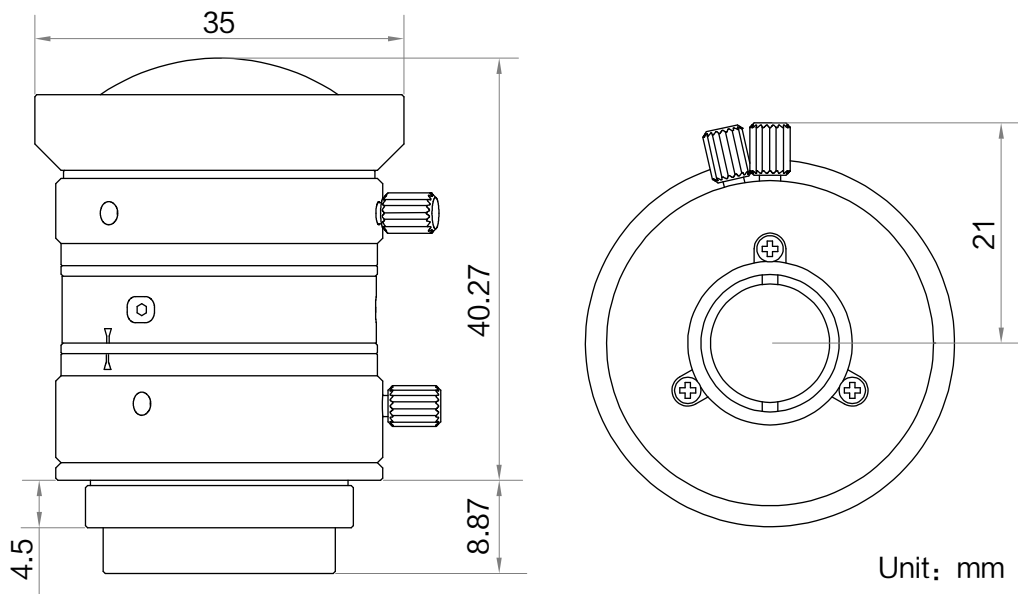

## Field of View

Extension (mm)	Working Distance (mm)		Magnification	Field of View (mm)					
				2/3"		1/1.8"		1/2"	
				H (8.45mm)	V (7.07mm)	H (7.38mm)	V (4.92mm)	H (6.22mm)	V (4.67mm)
2	near	8.86	-0.319	26.49	22.16	23.13	15.42	19.50	14.64
	far	15.46	-0.250	33.79	28.27	29.51	19.67	24.87	18.67
1	near	25.02	-0.194	43.56	36.44	38.04	25.36	32.06	24.07
	far	47.43	-0.125	67.56	56.52	59.00	39.33	49.73	37.34
0		100	-0.069	125.75	104.62	109.35	72.25	91.75	68.52
		150	-0.049	183.02	151.33	159.26	105.19	133.67	99.74
		200	-0.037	230.95	192.65	201.25	133.40	169.16	126.55
		250	-0.030	282.15	235.78	246.01	163.27	206.91	154.91
		300	-0.025	334.04	279.34	291.36	193.49	245.13	183.59
		350	-0.022	395.07	328.41	344.53	228.43	289.73	216.66
		400	-0.019	437.82	366.46	382.07	253.93	321.57	240.96
		450	-0.017	489.71	410.03	427.42	284.16	359.80	269.64
		500	-0.016	545.97	456.36	476.48	316.62	401.04	300.41
		550	-0.014	598.28	500.19	522.19	347.05	439.55	329.30
		600	-0.013	650.58	544.01	567.90	377.49	478.06	358.18
		650	-0.012	702.89	587.84	613.60	407.92	516.57	387.07
		700	-0.011	756.08	632.22	660.06	438.82	555.69	416.38
		800	-0.010	860.81	719.95	751.58	499.75	632.80	474.20
		900	-0.009	965.54	807.68	843.09	560.59	709.91	532.03
	1000	-0.008	1070.95	895.82	935.18	621.97	787.48	590.18	

# HIKROBOT

Hangzhou Hikrobot Co. Ltd.  
en.hikrobotics.com

© Hangzhou Hikrobot Co., Ltd. All Rights Reserved.

Hangzhou Hikrobot does not tolerate any infringement. Any organization or individual may not imitate or reproduce in whole or in part of the content. The data herein is based on Hikrobot's internal evaluation. Actual data may vary depending on specific configuration and operating condition. The information herein is subject to change without notice. All the content has been checked conscientiously. Nevertheless, Hikrobot shall not be liable to damages resulting from errors, inconsistencies or omissions.